

# SCHNEL

PROFESSIONAL SECURITY EQUIPMENT

## SC-700LIRDP

960H 700 TV LINE ULTRA HIGH RESOLUTION INDOOR IR DOME CAMERA

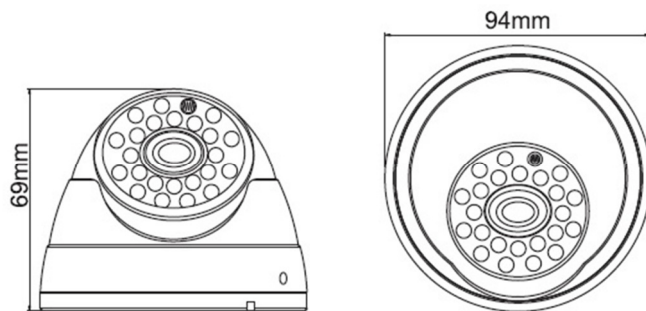

### Feature

3-Axis Plastic Dome Camera  
IR LED: Ø5X24PCS IR range: 20M  
3.6mm/F2.0 Fixed Lens  
Size: Ø94 x 69(H) mm

<b>Image Sensor</b>	1/3" SONY CCD
<b>Horizontal Resolution</b>	960H, 700TVL, Low Illumination, DWDR, OSD, DNR, UTC Effio-E
<b>Pixels</b>	PAL:976(H)x582(V )
<b>IR Series Distance</b>	20 M
<b>IR LED</b>	Ø5 X 24 PCS
<b>Lens</b>	3.6mm / F2.0
<b>Sync System</b>	Internal
<b>Usable Illumination</b>	0.001Lux/F2.0
<b>S/N Ratio</b>	≥52dB (AGC OFF)
<b>Gamma Correction</b>	0.45
<b>Video Out</b>	Composite Signal (1.0Vp-p, 75Ω)
<b>Scanning System</b>	PAL:625 Lines, 50 Field/Sec
<b>Electronic Shutter Time</b>	Auto:PAL 1/50-1/100, 000Sec
<b>Operation Temperature</b>	-10°C ~ +50°C RH95% Max
<b>Storage Temperature</b>	-20°C ~ +60°C RH95% Max
<b>White Balance</b>	Auto
<b>Power Source</b>	DC12V 150mA
<b>Dimension</b>	Ø94 x 69(H) mm
<b>Weight</b>	300g